

1
2
3 **UNITED STATES DISTRICT COURT**
4 **NORTHERN DISTRICT OF CALIFORNIA**

5 AUDLEY BARRINGTON LYON, JR., JOSÉ) Case No. 3:13-cv-05878-EMC
6 ELIZANDRO ASTORGA-CERVANTES, and)
7 NANCY NERIA-GARCIA , on behalf of)
8 themselves and all others similarly situated,)

9 *Plaintiffs,*)

10 v.)

11 UNITED STATES IMMIGRATION AND)
12 CUSTOMS ENFORCEMENT; SARAH)
13 SALDAÑA, Director of U.S. Immigration and)
14 Customs Enforcement; UNITED STATES)
15 DEPARTMENT OF HOMELAND)
16 SECURITY; JEH JOHNSON, Secretary of)
17 Homeland Security; and ADRIAN MACIAS,)
18 Acting Director of the San Francisco Field)
19 Office of U.S. Immigration and Customs)
20 Enforcement.¹)

21 *Defendants.*)

22 **SETTLEMENT AGREEMENT AND RELEASE**

23 Plaintiffs in the above-captioned matter, on behalf of themselves and all Class Members, and
24 Defendants U.S. Immigration and Customs Enforcement (“ICE”); Sarah Saldaña, in her official
25 capacity as Director of U.S. Immigration and Customs Enforcement; United States Department
26 of Homeland Security; Jeh Johnson, in his official capacity as Secretary of Homeland Security;
27 and Adrian Macias, in his official capacity as Acting Director of the San Francisco Field Office
28 of U.S. Immigration and Customs Enforcement, Enforcement and Removal Operations; by and

¹ Sarah Saldaña, Director, ICE, is substituted under Federal Rule of Civil Procedure 25(d) for Acting Director John Sandweg, who was originally named as an official-capacity Defendant in this Action. Adrian Macias, Acting Field Office Director, is substituted under Federal Rule of Civil Procedure 25(d) for former Field Office Director Timothy Aitken, who was originally named as an official-capacity Defendant in this Action.

1 through their attorneys, hereby enter into this Settlement Agreement and Release (“Agreement”),
2 as of the date it is executed by all parties hereto (the “Agreement Date”) and effective upon
3 approval of the Court pursuant to Rule 23 of the Federal Rules of Civil Procedure as set forth
4 below.

4 WHEREAS:

- 5
- 6 A. On December 19, 2013, Plaintiffs commenced a civil action against Defendants on behalf
7 of themselves and all others similarly situated, captioned *Lyon et al. v. U.S. Immigration*
8 *and Customs Enforcement, et al.*, United States District Court for the Northern District of
9 California Case No. 3:13-cv-05878-EMC (the “Action”) and sought class certification,
10 designation of Class Counsel, and declaratory and injunctive relief.
- 11 B. On April 16, 2014, the United States District Court for the Northern District of California
12 (the “Court”) certified the proposed class under Federal Rule of Civil Procedure 23(b)(2).
13 The Court defined the certified class as: “All current and future immigration detainees
14 who are or will be held by ICE in Contra Costa, Sacramento, and Yuba Counties.”
- 15 C. Plaintiffs moved to amend the class certification order and class definition on June 11,
16 2015, and the Court granted Plaintiffs’ motion and modified the definition of the certified
17 class on July 27, 2015. The Court endorsed the modified class definition pleaded in
18 Plaintiffs’ Supplemental Complaint: “All current and future adult immigration detainees
19 who are or will be held by ICE in Contra Costa County, Kern County, Sacramento
20 County, or Yuba County.”
- 21 D. Defendants deny all liability with respect to the Action, deny that they have engaged in
22 any wrongdoing, deny the allegations in the Complaint, deny that they committed any
23 violation of law, deny that they acted improperly in any way, and deny liability of any
24 kind to the Plaintiffs or Class Members, but have agreed to the settlement and dismissal
25 of the Action with prejudice in order to: (i) avoid the substantial expense, inconvenience,
26 and distraction of further protracted litigation, including trial and appeal; and (ii) finally
27 put to rest and terminate the Action and any and all Settled Claims as defined in Section
28 I.G.
- E. Both Plaintiffs and Defendants, through counsel, have conducted discussions and arm’s
length negotiations regarding a compromise and settlement of the Action with a view to
settling all matters in dispute.

1 F. Considering the benefits that the Plaintiffs and Class Members will receive from
2 settlement of the Action and the risks of litigation, Class Counsel have concluded that the
3 terms and conditions of this Agreement are fair, reasonable, and in the best interests of
4 the Plaintiffs and Class Members; Plaintiffs have agreed that Defendants shall be released
5 from the Settled Claims pursuant to the terms and provisions of this Agreement; and have
6 agreed to the dismissal with prejudice of this Action and all Settled Claims as defined in
7 Section I.G.

8 NOW, THEREFORE, it is hereby STIPULATED AND AGREED, by and among the parties to
9 this Agreement, through their respective attorneys, subject to the approval of the Court pursuant
10 to Rule 23(e) of the Federal Rules of Civil Procedure, in consideration of the benefits flowing to
11 the parties hereto from the Agreement, that the Settled Claims shall be compromised, settled,
12 forever released, barred, and dismissed with prejudice, upon and subject to the following terms
13 and conditions:

14 **I. DEFINITIONS:**

15 Wherever used in this Agreement, the following terms have the meanings set forth below:

- 16 A. “Action” means the civil action captioned *Lyon et al. v. U.S. Immigration and*
17 *Customs Enforcement, et al.*, Case No. 3:13-cv-05878-EMC, United States District
18 Court for the Northern District of California.
- 19 B. “Effective Date of Settlement” or “Effective Date” means the date upon which this
20 Agreement shall become effective, as set forth in Section VIII, below.
- 21 C. “Plaintiffs” means Audley Barrington Lyon, Jr., José Elizandro Astorga-Cervantes,
22 and Nancy Neria-Garcia.
- 23 D. “Class Member(s)” means any current or future adult immigration detainee who,
24 during the period of this Agreement, is or will be held by ICE in Contra Costa
25 County, Kern County, Sacramento County, or Yuba County.
- 26 E. “Plaintiffs’ Counsel” or “Class Counsel” means Julia Harumi Mass, Angélica
27 Salceda, Christine Sun, and Michael Risher of the American Civil Liberties Union
28 (“ACLU”) of Northern California; Carl Takei of the ACLU National Prison
Project; Robert Varian, Charles Ha, and Alexis Yee-Garcia of Orrick, Herrington &
Sutcliffe LLP; and Megan Sallomi and Marc Van Der Hout of Van Der Hout,
Brigagliano & Nightingale, LLP. Should these entities change their names or
merge with other entities, those new entities shall also qualify as Class Counsel.

- 1 F. “Defendants” means United States Immigration and Customs Enforcement
2 (“ICE”); Sara Saldaña, in her official capacity as Director of ICE; United States
3 Department of Homeland Security; Jeh Johnson, in his official capacity as
4 Secretary of Homeland Security; and Adrian Macias, in his official capacity as
5 Director of the San Francisco Field Office of ICE, their predecessors and
6 successors, their departments and agencies, and their past or present agents,
7 employees, and contractors.
- 8 G. “Settled Claims” means all claims for declaratory or injunctive relief that were
9 brought on behalf of Class Members based on the facts and circumstances alleged
10 in the Complaint and First Supplemental Complaint including but not limited to
11 claims that the telephone access afforded Class Members while in ICE custody
12 violated Class Members’ statutory rights and privileges under the Immigration and
13 Nationality Act, 8 U.S.C. § 1101 *et seq.*, including access to counsel and their right
14 to present evidence in certain immigration proceedings; their rights to due process
15 under the Fifth Amendment to the U.S. Constitution; and their rights to petition the
16 government for redress of grievances under the First Amendment to the U.S.
17 Constitution.
- 18 H. “Settlement” means the settlement provided for in this Agreement.
- 19 I. “Contra Costa” means West County Detention Facility in Contra Costa County,
20 California.
- 21 J. “Yuba” means Yuba County Jail in Yuba County, California.
- 22 K. “RCCC” means Rio Cosumnes Correctional Center in Sacramento County,
23 California.
- 24 L. “Mesa Verde” means Mesa Verde Detention Facility in Kern County, California.
- 25 M. “Facilities” means Contra Costa, Yuba, RCCC, and Mesa Verde.
- 26 N. “Housing Unit Phones” means the telephones located in or near housing units at the
27 Facilities that Class Members may utilize for both Legal Calls and other telephone
28 calls.
- O. “Phone Rooms” means the telephone-equipped enclosed rooms at Yuba, Contra
Costa, and Mesa Verde and the enclosed space ICE will add at RCCC to provide
free, direct, and non-monitored telephones for the Plaintiff Class.
- P. “Legal Calls” means calls to attorneys and calls to third parties to facilitate the
gathering of evidence and obtaining legal advice and representation related to the
class member’s immigration case. Such third parties include but are not limited to:
government agencies, courts, employers, businesses, organizations, and friends and

1 family members who may be testifying as witnesses, writing letters of support,
2 and/or assisting the class member to find an attorney or obtain evidence.

- 3 Q. "Attorney Legal Call" means a Legal Call to an attorney regarding prospective,
4 current, or past representation or for legal consultation. An Attorney Legal Call
5 shall not require the attorney to have a G-28 on file for the detainee.
- 6 R. "Non-Attorney Legal Call" means any Legal Call other than an Attorney Legal
7 Call.
- 8 S. "Positive Acceptance" means the requirement that for a telephone call to connect,
9 the recipient must listen to a recorded message and take an affirmative step,
10 typically pressing a particular key, to accept the call.
- 11 T. "Attorneys Performing Pro Bono Work" means any attorney who performs pro
12 bono work as a part of their practice, and not just attorneys who exclusively
13 perform pro bono work.
- 14 U. "Government Agencies and Offices" means federal, state, or local governmental
15 agencies and offices that may facilitate the gathering of evidence for immigration-
16 related proceedings and includes the following types of entities: California state
17 courts, U.S. District Courts in California, the Ninth Circuit Court of Appeals,
18 Federal and State Public Defender offices in California, major California Police,
19 Sheriff, District Attorney, and Probation Departments, and northern California
20 rehabilitation programs.
- 21 V. "Indigent Class Members" means Class Members who have had \$15 or less on
22 their commissary accounts for the previous ten days.
- 23 W. "Lockdown" means a restriction to cells or bunks during waking hours in response
24 to a specific security incident; it does not include routine "free time" limitations at
25 Contra Costa.
- 26 X. "Free Call" and "Free Calling" mean calls and calling where the call takes place at
27 no cost to the caller and the recipient.
- 28 Y. "ICE DTS Provider Pro Bono Platform" means the Pro Bono Platform provided by
ICE's Detainee Telephone Service ("DTS") Provider pursuant to a contract
between ICE and the ICE DTS Provider. The current ICE DTS Provider is Talton
Communications, Inc.

II. **RELEASE: SCOPE AND EFFECT OF RELEASE**

- A. As of the Effective Date, the Plaintiffs and the Class Members, on behalf of
themselves, their heirs, executors, administrators, representatives, attorneys,
successors, assigns, agents, affiliates, and partners, and any persons they represent,

1 by operation of any final judgment entered by the Court, fully, finally, and forever
2 release, relinquish, and discharge the Defendants of and from any and all of the
3 Settled Claims. The foregoing release includes all claims for injunctive or
4 declaratory relief, whether known or unknown, that could have been brought on
5 behalf of Class Members at any time prior to the Effective Date. This Release shall
6 not apply to claims that arise or accrue after the termination of this Agreement.

- 7 B. Defendants agree and acknowledge that this Agreement, and specifically this
8 release, shall not impact any individual Class Member's (other than the named
9 Plaintiffs') ability to bring a claim for monetary damages in his or her individual
10 capacity arising from or related to injury suffered as a result of limitations or denial
11 of telephone access while in ICE custody. Defendants also agree and acknowledge
12 that this Agreement, and specifically this release, shall not impact any individual
13 Class Member's (other than the named Plaintiffs') ability to argue (whether on a
14 Petition for Review, motion to reopen, or other appeal, application, request for
15 review of petition to modify such class member's order of removal or other
16 immigration order) that limitations on telephone access in ICE custody affected
17 such individual Class Member's immigration proceedings.

18 **III. TELEPHONE ACCESS IN THE FACILITIES**

19 **A. Adding Free and Private Numbers to Housing Unit Phones**

- 20 1. At Contra Costa, Yuba, and RCCC, the telephone numbers for certain
21 Government Agencies and Offices and Attorneys Performing Pro Bono Work
22 (as further identified in Paragraphs A.4 and A.5 below) shall be added to Free
23 Call telephone platforms that enable Class Members to make Free Calls to
24 these numbers from Housing Unit Phones without Positive Acceptance and
25 without being recorded or monitored.
- 26 2. At Mesa Verde, the telephone numbers for certain Government Agencies and
27 Offices and Attorneys Performing Pro Bono Work (as further identified in
28 Paragraphs A.4 and A.5 below) shall be added to a database of telephone
numbers that shall connect from the Mesa Verde Housing Unit Phones
without Positive Acceptance and without being recorded or monitored. If
technologically feasible, such numbers will also be Free Calls from the Mesa
Verde Housing Unit Phones.
3. In addition to the Free Call platforms described in paragraphs A.1 and A.2,
each of the Facilities shall enable Housing Unit Phones to make paid calls to
attorney telephone numbers without Positive Acceptance and without being
recorded or monitored. The attorney numbers shall be identified through the
process described in paragraphs A.5, 6, 7 and 8.

- 1 4. Plaintiffs shall provide lists of Government Agencies and Offices and
2 Defendants shall ensure their inclusion on the Free Call platforms and
3 database described in paragraphs A.1 and 2 above. Plaintiffs shall specify no
4 more than 10 rehabilitation centers for inclusion on each Facility's platform or
5 database.
- 6 5. Attorneys may request that their phone numbers be added to the platforms and
7 databases described in Paragraphs A.1, A.2, or A.3 by emailing the number
8 and specific request to an email drop box to be provided by ICE. If an attorney
9 requests to be added to the Free Call platforms, the attorney's telephone
10 number shall be added to the platforms described in A.1 and A.2 if s/he is an
11 Attorney Performing Pro Bono Work. If an attorney requests to be added to
12 the no-Positive-Acceptance databases, the attorney's telephone number shall
13 be added to the databases described in A.3 regardless of whether s/he is an
14 Attorney Performing Pro Bono Work.
- 15 6. Attorneys may request that their phone numbers be removed from the
16 platforms and databases described in Paragraphs A.1, A.2, or A.3 by emailing
17 the specific request to the same email drop box to be provided by ICE.
- 18 7. The parties will work together to develop a notice to immigration attorneys
19 practicing in the San Francisco Immigration Court to allow them to be added
20 to the Free Call platforms and/or database of numbers not subject to Positive
21 Acceptance and recording and/or monitoring. Class Counsel will reach out to
22 organizations including American Immigration Lawyers Association, National
23 Lawyers Guild, and/or Federal Bar Association to request use of their email
24 listservs for this purpose
- 25 8. Class Members may submit attorney names and telephone numbers to ICE for
26 addition to the platforms and databases described in paragraphs A.1, 2, and 3.
27 If the attorney identified by the Class Member confirms that s/he wishes to be
28 added, ICE shall add the attorney's telephone number to the platforms and
databases described in paragraph A.1 and A.2 (provided the attorney accepts
some pro bono immigration cases), or to the database described in paragraph
A.3
9. Platforms and databases described in A.1, A.2, and A.3 shall be updated
regularly, and no less than once a week, in response to requests under
paragraphs A.5, 6, 7, and 8.
10. Platforms and databases described in A.1, 2, and 3 shall be able to connect to
the telephone numbers for attorneys, Government Agencies and Offices
regardless of whether the numbers are toll-free or regular area code numbers.

1 (including but not limited to segregation, subject to paragraph D.3 below)
2 shall receive access to a phone booth (or other private area, as appropriate)
3 within two waking hours of making a request. If the request is made at or
4 before 3:00 p.m., the Class Member shall receive access to a phone booth or
5 other private area within business hours on the day of the request. Further
6 delays may be justified by a lockdown of unusual length or other
7 extraordinary circumstances, but shall in all cases be documented and reported
8 to ICE. Each Facility shall establish a process for such class members to
9 notify the facilitator as needed to assist with calls. In some instances, the
10 housing unit officer will contact the facilitator rather than having the Class
11 Member directly contact the facilitator.

- 12
- 13 3. The above requirements apply fully to Class Members in segregation for
14 administrative reasons. However, if a Class Member is in segregation for
15 disciplinary reasons and restrictions have been properly imposed on that Class
16 Member's general telephone calling privileges as part of the disciplinary
17 process, the above requirements regarding access to phone booths or other
18 private areas shall apply only to calls for personal or family emergencies,
19 Legal Calls, or otherwise justified by a compelling need.

20

21

22

23

24

25

26

27

28

E. Phone Rooms

1. ICE and the Facilities shall provide one or more Phone Rooms for Legal
Calls, including both Attorney Legal Calls and Non-Attorney Legal Calls, at
each Facility. A class member may request an Attorney Legal Call from the
Phone Room without first utilizing the Housing Unit Phones for particularly
sensitive or lengthy legal consultations. To make a Non-Attorney Legal Call
from the Phone Room, however, Class Members must first try to contact the
intended call recipient from the Housing Unit Phones and be unsuccessful.
2. With respect to RCCC, the Phone Room(s) provided may consist of an
enclosed room or another enclosed space (which may be a phone booth with
seating or another type of enclosed space located in the RCCC law library).
This shall ensure that Class Members can make free, direct, unrecorded and
unmonitored phone calls without being overhead by officers, other Facility
staff, or other Class Members or inmates of the Facility.
3. To accommodate interim Legal Call access at Contra Costa, whose system
currently will not allow the suspension of Positive Acceptance for paid calls
from housing unit phones and phone booths, ICE shall provide additional
Phone Room access. This requirement can be met by providing private
telephones without Positive Acceptance, such as phone booths equipped with
the same telephone systems as the telephones in the Phone Rooms either in

1 the housing units or elsewhere in the Facility, as long as access to those
2 telephones complies with the other provisions of this section.

- 3
- 4 4. ICE shall ensure that Class Members can use at least one of the telephones in
5 the Yuba Phone Room without being overheard by officers, other staff, or
6 other detainees. Options include changing Yuba's policy to limit use of the
7 Phone Room to one person at a time and installing a phone booth within the
8 Phone Room for one or both of the existing phones. Yuba Phone Room
9 phones shall not include a Positive Acceptance feature or automated outgoing
10 message.
- 11 5. Requests for Legal Calls will ordinarily be accommodated within eight facility
12 waking hours and shall be accommodated within 24 hours. Further delays may
13 be justified by extraordinary circumstances, but shall in all cases be
14 documented and reported to ICE.
- 15 6. Phone Room calls shall be scheduled for 30 minutes unless a detainee
16 specifies on his/her request form that a longer call will be needed. Facilities
17 shall accommodate requests for calls longer than 30 minutes. ICE reserves
18 the right to impose time limits on Phone Rooms in periods of high demand to
19 facilitate equal access for all detainees, consistent with the other terms of this
20 Agreement. Such time limits shall not be shorter than 20 minutes per call.
- 21 7. Each Facility shall modify its current request form for Class Members to
22 request access to Facility Phone Rooms as follows: The form shall include a
23 statement that Phone Room calls will be limited to 30 minutes unless the
24 Class Member indicates that a longer call is required, a space for class
25 members to request a particular time for Phone Room access and to indicate if
26 more than 30 minutes will be needed, and spaces for Class Members to
27 provide the name of the individual, agency or organization the Class Member
28 seeks to contact and the telephone number the Class Member wishes to call.
8. Attorneys may request to schedule a Legal Call in a Phone Room through the
on-site facilitators at each Facility or other Facility staff. Such requests shall
be granted within the same time limits that apply to Class Member requests
for Phone Room access as set forth in Paragraph E.5 above. Further delays
may be justified by extraordinary circumstances, but shall in all cases be
documented and reported to ICE.
9. The Facilities' advance vetting and scheduling of call requests shall be
performed as follows:
- i. Advance vetting shall be limited to internet searches. Facilities shall
not directly contact the individual/entity sought to be contacted in
advance of the call, except to contact an attorney who requests to
schedule a call with a Class Member.

1 Agreement, including calls from the Housing Unit Phones, phone booth
2 phones, and Phone Room phones.

- 3 3. The individuals who act as on-site facilitators may be assigned to limited other
4 duties as long as such duties do not prevent the facilitators from facilitating
5 class members' requests for Legal Calls in a timely manner.

6 H. Accommodations for Indigent Class Members

- 7 1. ICE shall provide accommodations for free Legal Calls to Indigent Class
8 Members.
9 2. Indigence shall be determined at the time of the initial call request, and each
10 subsequent request for additional time.
11 3. ICE shall provide accommodations to Indigent Class Members by either
12 allowing extra access to Phone Rooms or by providing phone credit for
13 Housing Unit Phones. Such phone credit shall be provided in amounts of at
14 least 30 minutes per request.

15 I. International Calling

- 16 1. ICE shall provide international call access for Legal Calls to Class Members,
17 during Facility waking hours, with advance notice and as set forth below.
18 2. If possible, international calling for Legal Calls will be made available
19 through a Facility Phone Room in accordance with the procedures for
20 accessing the Facility Phone Room in Section III.E.
21 3. If possible, free international calling for Legal Calls for Indigent Class
22 Members will be made available in accordance with the procedures for
23 Accommodations for Indigent Class Members in Section III.H.
24 4. If international calling for Legal Calls is not available through the Housing
25 Unit Phones or Facility Phone Rooms in accordance with the above
26 procedures, ICE shall accommodate requests for international Legal Calls in
27 the Facility through other means. This may include providing a cell phone
28 enabled with international calling through visiting ICE agents. If such other
means are required, ICE will accommodate requests for international Legal
Calls within no more than 72 hours of the request and will allow Indigent
Class Members access to free international Legal Calls through these alternate
means.
5. On the rare occasion that a Class Member presents a compelling need for
international Legal Call access outside of facility waking hours (e.g. to contact
a business or agency within country business hours that do not overlap with
facility waking hours), ICE shall make reasonable accommodations to
facilitate the Class Member's timely communication with that entity.

J. Three Way Calling

- 1 1. Upon request based upon a stated need, such as needing an interpreter to join
2 a call, ICE shall facilitate three-way calls in the Facility where the detainee is
3 housed or at the nearest ICE field office. ICE shall attempt to accommodate
4 such calls at the Facility, if possible, before transporting a Class Member to
5 the field office for such a call.

6 K. Notice to Plaintiff Class Members of Telephone Options

- 7 1. ICE and the Facilities shall ensure that Class Members are informed that they
8 must contact an ICE officer or a Facility staff member (such as the on-site
9 facilitator or the housing unit officer) if they have difficulty making a Legal
10 Call.
11 2. An instruction sheet shall be printed and posted in at least English and
12 Spanish, explaining all telephone access options, how to use the telephones
13 and platforms available to ICE detainees, and how to make additional requests
14 for telephone access, in clear, step-by-step instructions. The instruction sheet
15 shall be posted in English and Spanish near the Facility phones. ICE and the
16 Facilities shall instruct their officers to show the instruction sheet to any Class
17 Member who requests assistance with making phone calls and explain its
18 provisions.
19 3. Plaintiffs agree to produce a video that conforms to Americans with
20 Disabilities Act standards, with content and format to be approved by ICE, to
21 explain telephone access options available to Class Members. This video shall
22 be shown regularly in the Facilities, such that newly-admitted Class Members
23 are generally shown the video within one week of arrival.

24 L. Accommodations for Language Minorities

- 25 1. Facilities shall, if local resources are not adequate or available, use a language
26 line to provide interpretation of telephone materials and instructions upon the
27 request of any Class Member who is unable to read English or Spanish, not to
28 include a full translation of the detainee handbook.
29 2. ICE shall post a notice near the Housing Unit Phones in the Facilities in the
30 ten written languages most commonly used by respondents in the San
31 Francisco Immigration Court, instructing individuals to ask the facilitator or
32 housing unit officer for interpretation of telephone access instructions and
33 assistance accessing telephones. The speed dial code for the ACLU of
34 Northern California shall be included on this notice as a resource for reporting
35 problems obtaining telephone access.
36 3. Class members attempting to call individuals who do not speak English and
37 do not understand the prompts to accept a call from the Facility shall be

provided access to Phone Room calls in accordance with the Phone Room request process described in Section III.E.

IV. IMPLEMENTATION AND OVERSIGHT

A. Contracts with Facilities

1. The terms of this Agreement that describe requirements to be fulfilled by Facilities alone or in conjunction with ICE shall be specified in contracts between ICE and the Facilities.
2. ICE shall complete the contracting process and implement the requirements of the Agreement within one year of the Agreement's Effective Date. However, to the extent compliance with a particular requirement of the Agreement is impracticable (as that term is defined under federal common law), Defendants' failure to implement that requirement will not be a violation of the Agreement.
3. Within 30 days of determining it will not complete a contract with a Facility and at least 60 days prior to transferring class members from that Facility, in anticipation of contract cancellation, Defendants shall notify Class Counsel and the Parties shall meet and confer to provide adequate telephone access to the affected Class Members in the counties covered by this Agreement, possibly to include modifying the Agreement. If the Parties are unable to reach agreement, they shall refer the dispute to this Agreement's alternative dispute resolution process under the terms of the existing Agreement.

B. Compliance with contract terms shall be monitored by ICE Contracting Officer's Representative (COR) and Contracting Officer's Technical Representative (COTR), as well as by other ICE personnel visiting the facilities, who will report compliance/non-compliance to the COR/COTR. Failure to meet Settlement terms by the Facilities shall be treated as a contract deficiency and addressed through the cure process used by CORs/COTRs.

C. ICE shall require training of all local ICE personnel with duties related to detention management and oversight as well as Facility staff whose duties include supervising detainees or responsibilities related to detainee phone access in the Facilities. This training shall include the requirements of this Agreement, applicable ICE detention standards for telephone access, and the policies and procedures for implementation of this Agreement at the Facility/ies relevant to the particular individuals being trained.

D. Within 180 days of the Agreement's Effective Date, ICE shall modify forms used during weekly Facility Liaison Visits and the annual ERO Detention Management Division (G324A) audit (currently carried out by the Nakamoto Group, Inc.) to evaluate compliance with each of the following:

1. When a detainee requests a direct or free Legal Call to an attorney, court, or government agency or demonstrates a compelling need for other direct

1 or free calls, access is granted within 24 hours of the request and
2 ordinarily within 8 facility waking hours. Further delays may be justified
3 by extraordinary circumstances.

- 4 2. The facility documents and reports to ICE/ERO any delays in responding
5 to requests for free or direct Legal Calls beyond 8 facility waking hours.
- 6 3. Detainees are provided private settings for Legal Calls such that calls
7 cannot be overheard by officers, other staff, or other detainees.
- 8 4. The facility has a system for taking and delivering telephone messages to
9 detainees, including but not limited to attorney messages, other messages
10 related to a detainee's legal case, and emergency messages, and ensures
11 the timeliness of such message delivery.
- 12 5. The facility provides translation and interpretation services to detainees
13 who are unable to read written telephone access rules in the languages
14 provided.
- 15 6. Detainees in segregation or other environments with limited physical
16 access to telephones have reasonable and equitable access to telephones
17 during waking hours (i.e., they can request telephone calls and receive
18 them in a timely manner).

14 **V. ENFORCEMENT AND MONITORING**

- 15 A. Plaintiffs' counsel shall be provided with the following records within 45 days of the
16 Agreement's Effective Date or 45 days of finalizing the particular record, whichever
17 is later, to the extent such records are or were created after November 19, 2015,
18 through the termination of this Agreement:
 - 19 1. Amendments/modifications that relate to telephone access or other issues
20 outlined in this Agreement to Facility contracts to which ICE is a party or
21 authorized rider for Mesa Verde, RCCC, Contra Costa, and Yuba;
 - 22 2. Amendments, modifications, or new contracts for ICE Detainee Telephone
23 Service to the extent they are implemented at Mesa Verde (i.e., the contract
24 currently held by Talton);
 - 25 3. Any new contract for the Contra Costa jail account/phone management
26 system, once awarded;
 - 27 4. Any changes to Facility policies related to telephone access;
 - 28 5. Any modified templates or forms of internal compliance instruments,
worksheets, inspection reports, and similar documents that relate to telephone
standards, telephone access, and/or the terms of this Agreement; and
 6. Any revised orientation materials related to telephone access (unless Plaintiffs
are involved in drafting orientation materials and therefore already have
copies of the final orientation materials).

- 1 B. To the extent class members are relocated to different facilities within Contra Costa,
2 Yuba, Sacramento or Kern County for more than 10 days, ICE shall meet and confer
3 with Class Counsel to agree upon facility-specific provisions that may be necessary to
4 effectuate the intent of this Agreement at the different facility.
- 5 C. During the terms of this Agreement, Class Counsel shall be provided with the
6 following records:
7 1. Any Contract Discrepancy Reports (CDR) issued by the COTR to one of the
8 four detention service providers concerning a facility's failure to correct a
9 deficiency related to a provision of this Agreement.
10 2. The annual inspection report for telephone access by February 15th of the
11 calendar year following the inspection of each Facility.
12 3. Records reflecting notifications from the Facilities to ICE of the Facilities'
13 failure to accommodate a request for Phone Room access within 24 hours or
14 phone booth access within 2 hours.
- 15 D. In addition, on request, Class Counsel shall be provided with the following
16 documents covering a specified future month from a specified facility selected by
17 Class Counsel, not to exceed six selections a year:
18 1. Detainee kites and grievances to ICE relating to telephone access (including
19 responses); and
20 2. Weekly Telephone Serviceability Worksheets regarding that Facility.
- 21 E. ICE shall continue to conduct internal testing of Housing Unit Phones in accordance
22 with its current telephone serviceability report procedures and any changes that are
23 adopted pursuant to section IV.D of this Agreement.
- 24 F. ICE shall permit Class Counsel, with reasonable advance notice, to conduct
25 interviews with Class Members once per year per Facility. ICE shall ensure that
26 Facilities accommodate these interviews by providing Class Members a convenient
27 way to indicate their interest in participating in the interviews and facilitating group
28 or individual meetings between Class Counsel and willing Class Member
participants. These interviews are in addition to, not a substitute for, any interviews
that Class Counsel may schedule using each Facility's normal attorney meeting
procedures.

VI. DISPUTE RESOLUTION PROCEDURES; CONTINUING JURISDICTION

- 24 A. The Court shall retain jurisdiction to supervise the implementation of this
25 Agreement and to enforce its terms, and the terms of this Agreement shall be
26 incorporated into the Order of the Court approving the Agreement.
- 27 B. The parties agree that the Court will not be asked to exercise jurisdiction to
28 supervise the implementation of this Agreement or to enforce its terms until
exhaustion of the following dispute resolution process:

1. Should Class Counsel believe in good faith that Defendants are engaging in a pattern or practice of non-compliance with requirements of this Agreement at a specific Facility or Facilities, Class Counsel shall promptly notify counsel for Defendants, in writing, of the specific grounds upon which non-compliance is alleged. If Class Counsel so request after providing notice of noncompliance with respect to a specific Facility, Defendants shall commence retention within three business days (72 hours, not including weekends and holidays) of the detainee kites and grievances to ICE from that Facility regarding telephone access, and the detainee kites and grievances to that Facility regarding telephone access, including Class Member requests contemplated under Section III of this Agreement. Document retention shall continue for fourteen (14) days. Defendants' counsel shall forward the documents to Class Counsel after a reasonable period of internal processing, not to exceed five business days, not including weekends and holidays, after the end of the 14-day retention period.
2. Within thirty (30) calendar days after receipt of the notice from Class Counsel, counsel for Defendants shall notify Class Counsel of Defendants' position and any action it has taken or intends to take in connection therewith. The parties shall negotiate in good faith in an effort to resolve any remaining disputes. The parties agree that this negotiation period will be considered exhausted if the parties jointly determine that negotiations have reached an impasse, or if either party invokes the formal meet-and-confer process under paragraph 3 of Section VI.B. of the Agreement.
3. If any dispute cannot be resolved informally under paragraphs 1 or 2 of Section VI.B. of the Agreement, counsel for either party may notify counsel for the opposing party by letter and request that counsel meet and confer. The parties shall meet within ten (10) calendar days of such notice in an attempt to arrive at an amicable resolution of the dispute.
4. The parties may refer any unresolved dispute to Magistrate Judge Ryu for mediation. If Magistrate Judge Ryu is no longer available or does not consent to serve as mediator, the parties may refer the unresolved dispute to another magistrate judge in the Northern District of California for mediation, if the parties mutually agree on the mediator and such mediator consents. If the dispute has not been resolved through mediation within 14 days, counsel may mutually agree to continue mediation or counsel may seek to enforce the Agreement through a motion in district court. Additionally, if the parties cannot agree on a mediator, if no mutually-agreed-on mediator consents, or if

1 the parties mutually agree to bypass mediation, counsel may seek to enforce
2 the Agreement through a motion in district court.

3 5. If the parties do not reach resolution under the procedures of Paragraphs 1-4
4 of Section VI.B. of the Agreement, either party may then file a motion
5 requesting that the district court resolve the dispute.

6 6. The parties agree that the mediation process described in Section VI.B of the
7 Agreement shall be conducted confidentially and that no public disclosure
8 shall be made regarding the mediation process at any time before, during, or
9 after the mediation process, except that the final result of the mediation may
10 be disclosed. All documents and information disclosed by either party during
11 the mediation process shall not be admissible in any judicial proceeding. All
12 statements or conclusions of the mediator shall not be admissible in any
13 subsequent judicial proceeding.

14 C. The parties agree that any action or proceeding to enforce the terms of this
15 Agreement shall be brought exclusively in the United States District Court for the
16 Northern District of California. The Court in this proceeding shall have the power
17 to award such relief and issue such judgments as the Court deems proper and
18 appropriate.

19 **VII. TERMS OF ORDER FOR NOTICE, HEARING AND FINAL JUDGMENT**

20 A. Concurrently with their filing of this Agreement, Class Counsel shall apply to the
21 Court for Preliminary Approval of the Settlement provided for in this Agreement
22 and entry of a Preliminary Approval Order. Such Preliminary Approval will seek
23 approval of a Notice to the Class substantially in the form appended hereto as
24 Exhibit B, as well as a finding that the following satisfies the publication
25 requirements of Rule 23 of the Federal Rules of Civil Procedure: Within ten (10)
26 business days of the date of the Preliminary Approval, (i) posting the Notice to the
27 Class and this Settlement Agreement in appropriate places on the ICE public
28 website; (ii) providing the Notice to the Class and this Agreement to immigration
attorneys in the San Francisco Bay Area through the local American Immigration
Lawyers' Association and National Lawyers Guild listservs; (iii) providing the
Notice to the Class and this Agreement in appropriate places on the website of the
ACLU of Northern California; (iv) posting the Notice to the Class in all housing
units in the Facilities where Class Members are housed, in an area prominently
visible to immigration detainees; and (v) providing individual copies of the Notice
to the Class to any Class Members who are housed in segregation, medical,
holding, or other specialized units with restricted access to common areas during

1 Facility waking hours. The Notice to the Class and this Agreement shall remain
2 posted, and shall be maintained or replaced with new copies as needed, until the
3 Court issues an order finally approving or rejecting the Settlement. Class Counsel
4 shall be responsible for meeting the notice requirements listed in (ii)-(iii) above
5 and ensuring maintenance of such notice, and Defendant ICE shall be responsible
6 for meeting the notice requirements listed in (i), (iv) and (v) above and ensuring
7 maintenance of such notice. The parties shall request that Class Members be
8 provided at least forty-five (45) days to submit objections to the Court after the
9 Notice to the Class is posted and distributed.

10 B. If the Settlement contemplated by this Agreement is approved by the Court,
11 counsel for the parties shall request that the Court enter a Final Judgment
12 substantially in the form appended hereto as Exhibit C.

13 C. Within ten (10) business days following the Effective Date of Settlement, ICE shall
14 provide the Notice of Final Settlement substantially in the form appended hereto as
15 Exhibit D by posting it in all housing units in the Facilities where Class Members
16 are housed, in an area prominently visible to immigration detainees, as well as
17 providing individual copies of the Notice to the Class to any Class Members who
18 are housed in segregation, medical, holding, or other specialized units with
19 restricted access to common areas during facility waking hours. The Notice of Final
20 Settlement shall remain posted, and shall be maintained or replaced with new
21 copies as needed, until the obligations of this Agreement are terminated.

22 D. ICE shall post a Spanish language translation of both the Preliminary Notice and
23 the Final Notice to the Class. Should Class Counsel provide to ICE translations in
24 other languages, ICE shall post a notice informing Class Members that such
25 translations are available. Class Counsel shall provide such notices in sufficient
26 time to allow ICE to meet the posting requirements in Sections VII.A and C. of the
27 Agreement.

28 **VIII. EFFECTIVE DATE OF SETTLEMENT; TERMINATION**

29 A. The Effective Date of this Agreement shall be the date when all of the following
30 shall have occurred: (a) entry of the Preliminary Approval Order; (b) approval by
31 the Court of this Agreement, following notice to the Class and a fairness hearing, as
32 prescribed by Rule 23 of the Federal Rules of Civil Procedure; and (c) entry by the
33 Court of Final Judgment, in all material respects in the form appended hereto as
34 Exhibit C.

- 1 B. In the event that the Court does not approve the Agreement, or the Court's approval
2 of the Agreement or the Final Judgment is reversed, vacated, or terminated on
3 appeal, the parties' good-faith adherence to the terms of this Agreement prior to
4 said reversal, vacatur, or termination shall not be considered unlawful.
- 5 C. This Agreement is subject to and contingent upon Court approval under Rule 23(e)
6 of the Federal Rules of Civil Procedure. Defendants' Counsel and Class Counsel
7 shall have the right to terminate this Agreement by providing written notice of their
8 election to do so ("Termination Notice") to all other parties hereto within thirty
9 (30) days of (a) the Court's declining to enter the Preliminary Approval Order or
10 modifying that Preliminary Approval Order in any material respect; (b) the Court's
11 declining to approve the Settlement embodied in this Agreement or any material
12 part of it; (c) the Court's declining to enter the Final Judgment or modifying the
13 Final Judgment in any material respect; or (d) the Court of Appeals or the United
14 States Supreme Court's reversing, vacating, or modifying in any material way the
15 Final Judgment.
- 16 E. Except as otherwise provided herein, in the event the Settlement is terminated or
17 modified in any material respect or fails to become effective for any reason, then
18 the Settlement shall be without prejudice and none of its terms shall be effective or
19 enforceable; the parties to this Agreement shall be deemed to have reverted to their
20 respective status in the Action as of the date and time immediately prior to the
21 execution of this Agreement; and except as otherwise expressly provided, the
22 parties shall proceed in all respects as if this Agreement and any related orders had
23 not been entered. In the event the Settlement is terminated or modified in any
24 material respect, the parties shall be deemed not to have waived, not to have
25 modified, or not be estopped from asserting any additional defenses or arguments
26 available to them.

27 **IX. TERMINATION OF OBLIGATIONS**

28 Unless earlier terminated by operation of Section VIII, the obligations of this Agreement shall terminate within five (5) years of the Effective Date.

X. NO ADMISSION OF WRONGDOING

- A. This Agreement, whether or not executed, and any proceedings taken pursuant to it:
1. shall not be construed to waive, reduce, or otherwise diminish the authority of the Defendants to enforce the laws of the United States against Class Members,

1 consistent with the Constitution and laws of the United States, and applicable
2 regulations;

3 2. shall not be offered or received against the Defendants as evidence of, or
4 construed as or deemed to be evidence of, any presumption, concession, or
5 admission by any of the Defendants of the truth of any fact alleged by the
6 Plaintiffs or the validity of any claim that had been or could have been asserted
7 in the Action or in any litigation, or the deficiency of any defense that has been
8 or could have been asserted in the Action, or of any liability, negligence, fault,
9 or wrongdoing of the Defendants; or any admission by the Defendants of any
10 violations of, or failure to comply with, the Constitution, laws or regulations;
11 and

12 3. shall not be offered or received against the Defendants as evidence of a
13 presumption, concession, or admission of any liability, negligence, fault, or
14 wrongdoing, nor shall it create any substantive rights or causes of action against
15 any of the parties to this Agreement, in any other civil, criminal, or
16 administrative action or proceeding, other than such proceedings as may be
17 necessary to effectuate the provisions of this Agreement; provided, however,
18 that if this Agreement is approved by the Court, Defendants may refer to it and
19 rely upon it to effectuate the liability protection granted them hereunder.

20 **XI. ATTORNEYS' FEES**

21 As set forth below, within 65 days of the Effective Date, Defendants shall pay to Class Counsel
22 the sum of \$ 405,000 to settle and resolve Plaintiffs' claims to attorneys' fees and costs, if such
23 award is approved by the Court.

- 24 A. The parties agree to the "Attorneys' Fee Settlement Amount" of \$405,000, to avoid
25 further litigation and costs associated litigating a fee and cost request and to avoid
26 the risks attendant to such proceedings. Plaintiffs shall file a motion for fees under
27 Fed. R. Civ. P. 23(h) and 54(d)(2)).
- 28 B. Defendants agree not to oppose a motion seeking a fee award of \$405,000 or less.
- C. If for any reason the Court awards an amount in excess of \$405,000, Plaintiffs and
Class Counsel expressly disclaim any and all right to collect the amount that
exceeds \$405,000 from any person or entity, and agree, upon demand, to execute a
release of any person's or entity's obligation to pay such sums. In the event the
Court awards Class Counsel less than \$405,000, this Settlement Agreement shall

1 remain in full force and effect. Nothing in this Agreement waives or prevents
2 Plaintiffs and Class Counsel from appealing an award of less than \$405,000.

- 3 D. Subject to the foregoing provisions, Defendants shall deliver the Attorneys' Fee
4 Settlement Amount to Class Counsel by direct wire transfer into Class Counsel's
5 designated account. Class Counsel shall provide to Defendants all information
6 necessary to accomplish the direct wire transfer into that account within five days
7 of the Effective Date. Plaintiffs and Class Counsel acknowledge that payment of the
8 Attorneys' Fee Settlement Amount by Defendants or any of them in accordance
9 with the wire instructions shall resolve all of Defendants' liability for such amount.
- 10 E. Class Counsel shall be fully responsible for the allocation and payment of the
11 Attorneys' Fee Settlement Amount among themselves.
- 12 F. Defendants' payment of the Attorneys' Fee Settlement Amount shall satisfy any
13 claims by Plaintiffs' Counsel and/or Class Counsel for attorney fees and costs
14 related to and for the Action, including any fees and costs that may be incurred by
15 Plaintiffs' Counsel and/or Class Counsel in the course of monitoring the
16 implementation of this Agreement (except as set forth in Paragraph G). Plaintiffs,
17 Plaintiffs' Counsel, and Class Counsel, and their heirs, executors, administrators,
18 representatives, attorneys, predecessors, successors, assigns, agents, affiliates, and
19 partners, and any persons they represent, by operation of any final judgment entered
20 by the Court, fully, finally, and forever release, relinquish, and discharge the
21 Defendants of and from any and all claims for attorney fees and costs related to and
22 for the Action, including any fees and costs that may be incurred in the course of
23 monitoring the implementation of this Agreement (except as set forth in Paragraph
24 G).
- 25 G. In the event that Class Counsel seek to enforce the terms of the Agreement pursuant
26 to Section VI.C., nothing in this Agreement shall be interpreted as precluding
27 Plaintiffs from seeking attorneys' fees and costs solely for such enforcement action.
- 28 H. If either party terminates the Agreement under Section VIII.C because the Court of
Appeals or the United States Supreme Court reversed, vacated, or modified in any
material way the Final Judgment after the Effective Date, Plaintiffs agree that Class
Counsel shall return the Attorneys' Fee Settlement Amount, plus any interest
earned, to Defendants upon final resolution of the appeal. Final resolution of the
appeal occurs when all appellate remedies, including petitions for rehearing,
petitions for rehearing *en banc*, and petitions for certiorari or any other form of
review, have been finally disposed of in a manner that allows for termination of the
Agreement.

1 **XII. ADDITIONAL PROVISIONS**

- 2 A. This Agreement, and the obligations incurred herein, shall be in full and final
3 disposition of the Action with prejudice, including any and all Settled Claims against
4 Defendants. On the Effective Date, Plaintiffs and Class Members shall be deemed to
5 have fully, finally, and forever released, relinquished, and discharged Defendants of
6 and from any and all Settled Claims in accordance with Part II.
- 7 B. All of the exhibits attached hereto are hereby incorporated by reference as though
8 fully set forth herein.
- 9 C. This Agreement may not be modified or amended, nor may any of its provisions be
10 waived except by a writing signed by all parties hereto or their successors-in-interest.
- 11 D. The waiver by one party of any breach of this Agreement by any other party shall not
12 be deemed a waiver of any other prior or subsequent breach of this Agreement.
- 13 E. This Agreement and its exhibits constitute the entire agreement among the parties
14 hereto concerning the Settlement of the Action, and no representations, warranties,
15 or inducements have been made by any party hereto other than those contained and
16 memorialized in such documents.
- 17 F. This Agreement may be executed in one or more counterparts. All executed
18 counterparts and each of them shall be deemed to be one and the same instrument
19 provided that counsel for the parties to this Agreement shall exchange among
20 themselves original signed counterparts.
- 21 G. This Agreement shall be binding upon, and inure to the benefit of, the successors and
22 assigns of the parties hereto.
- 23 H. This Agreement shall not be construed more strictly against one party than another
24 merely by virtue of the fact that it, or any part of it, may have been prepared by
25 counsel for one of the parties, it being recognized by the parties that this Agreement
26 is the result of negotiations between the parties and that all parties have contributed
27 substantially and materially to the preparation of this Agreement.
- 28 I. All counsel and any other person executing this Agreement and any of the exhibits
hereto, or any related settlement documents, warrant and represent that they have the
full authority to do so and that they have the authority to take appropriate action
required or permitted to be taken under the Agreement to effectuate its terms.
- J. Class Counsel and Defendants' Counsel agree to cooperate fully with one another in
seeking Court approval of this Agreement and to promptly agree upon and execute
all such other documentation as may be reasonably required to obtain final approval
by the Court of the Settlement.

1 For and on behalf of Defendants:

2
3 EXECUTED this ___ day of _____, 2016.

4
5 **Katherine J. Shinnors,**

6 Trial Attorney, District Court Section

7 Office of Immigration Litigation

8 Civil Division

9 United States Department of Justice

10 P.O. Box 868, Ben Franklin Station Washington, D.C. 20044

11
12 **Counsel for Defendants**

13 For and on behalf of Plaintiffs and the Class:

14
15 EXECUTED this ___ day of _____, 2016.

16
17 **Julia Harumi Mass, Esq.**

18 American Civil Liberties Union
19 of Northern California, Inc.

20 39 Drumm Street

21 San Francisco, CA 94111

22 415-621-2493

23 415-255-8437 (fax)

24 jmass@aclunc.org

25
26 **Robert P. Varian**

27 Orrick, Herrington & Sutcliffe LLP

28 405 Howard Street

San Francisco, CA 94105

415-773-5700

415-773-5759 (fax)

rvarian@orrick.com

29
30 **Carl Takei**

31 American Civil Liberties Union

32 National Prison Project

33 915 15th Street, N.W., 7th Fl.

34 Washington, DC 20005

35 202-393-4920

36 202-393-4931 (fax)

37 ctakei@aclu.org

38 **Counsel for Plaintiffs**

39
40 **Marc Van Der Hout**

41 Van Der Hout, Brigagliano

42 & Nightingale LLP

43 180 Sutter Street, Suite 500

44 San Francisco, CA 94101

45 415-981-3000

46 415-981-3003 (fax)

47 MV@vblaw.com

EXHIBIT A

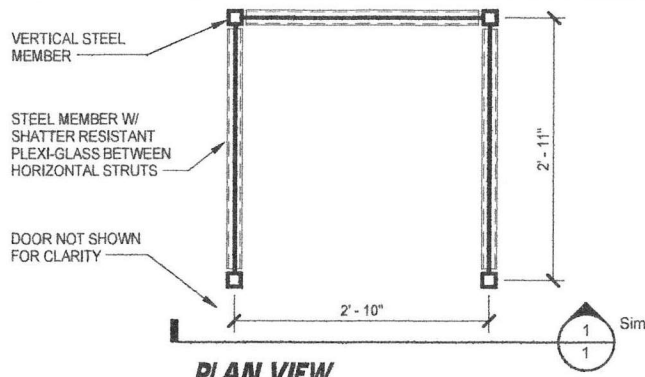

PLAN VIEW

3/4" = 1'-0"

CLEAR .118" SHATTER RESISTANT PLEXI-GLASS DOOR W/ HANDLE. SECURE TO STEEL FRAME WITH MAGNET DOOR LOCKS 4-5 LB PULL

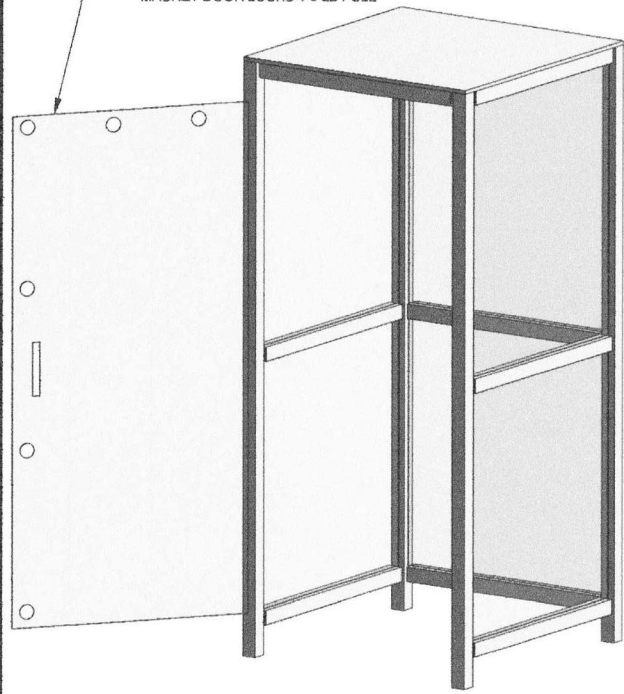

GENERAL NOTES

- NOTE:
 1. FRAME SHALL BE PAINTED WITH AN ALKYDED ENAMEL PAINT. COLOR CHOICE BY OWNER:
 -BLACK
 -GREY
 -YELLOW
 -RED
 -HAMMERTONE
 -COPPER

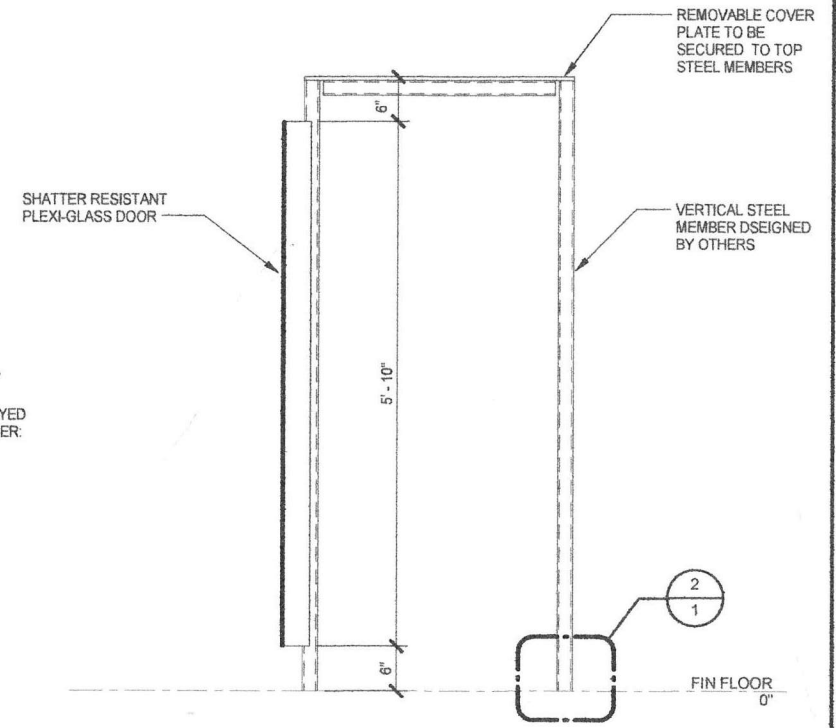

1 ELEVATION

3/4" = 1'-0"

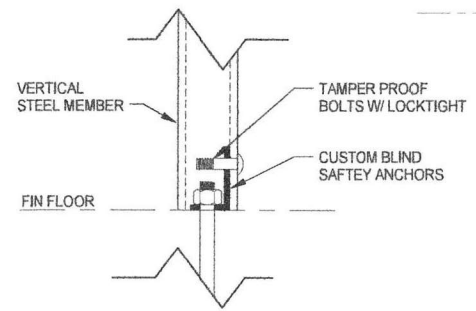

2 DETAIL

3" = 1'-0"

PHONE BOOTH

SHEET
1

EXHIBIT B

**NOTICE OF PROPOSED SETTLEMENT REGARDING TELEPHONE ACCESS IN
IMMIGRATION DETENTION**

LYON, ET AL. V. U.S. IMMIGRATION AND CUSTOMS ENFORCEMENT ET AL.,

Case No. 3:13-cv-05878-EMC

**IN THE UNITED STATES DISTRICT COURT
FOR THE NORTHERN DISTRICT OF CALIFORNIA**

TO: All current and future adult immigration detainees who are or will be held by ICE in Contra Costa County, Kern County, Sacramento County, or Yuba County.

Purpose of this Notice

This notice has three purposes: 1) to tell you about the proposed settlement and the fairness hearing in this class-action lawsuit; 2) to tell you how to obtain more information, including a copy of the full proposed settlement agreement; and 3) to explain how you may object to the proposed settlement if you disagree with it.

Background on the Lawsuit

This class action lawsuit asserts that U.S. Immigration and Customs Enforcement (ICE) does not provide adequate telephone access for immigration detainees housed in Contra Costa West County Detention Facility, Yuba County Jail, Rio Cosumnes Correctional Center (RCCC), and Mesa Verde Detention Facility (collectively, the Facilities). Specifically, the lawsuit asserts that ICE is violating the statutory and constitutional rights of immigration detainees because the telephone access conditions in the Facilities: (1) prevent detainees from retaining and communicating effectively with lawyers, and (2) prevent detainees from gathering evidence to present in immigration-related proceedings. The lawsuit seeks changes to ICE and Facility policies; it does not ask for money damages.

Class Counsel (representing the interests of detainees in the Facilities) and ICE's attorneys have negotiated a settlement. The Court has given preliminary approval to this settlement, and the next step is for the Court to consider any comments and objections from class members. A hearing has been scheduled for _____, 2016, at _____.m. before the Honorable Edward M. Chen of the United States District Court for the Northern District of California in Courtroom 5 – 17th Floor at the San Francisco Courthouse, 450 Golden Gate Ave., San Francisco, California. At this hearing, the Court will consider whether the proposed settlement is fair, reasonable, and adequate. The Court will then either approve the settlement or order the parties to continue litigating.

Description of the Proposed Settlement Agreement

Below is a summary of the key points in the settlement agreement. To get a copy of the full agreement, see the section entitled "For Further Information" after this summary.

1. **There will be more ways to make legal calls from housing unit phones and new phone booths for privacy in housing units.**
 - a. **ICE will add speed-dials to make free, direct, unmonitored calls to more government offices and some attorneys from the housing unit phones.** ICE will set up more speed-dial numbers (similar to ICE's pro bono platform) that will connect without needing a live person to answer and accept the call, that will not be recorded or monitored, and that will be cost-free for the caller and recipient. These numbers will include police departments, probation departments, state and federal courts, and rehabilitation centers as well as attorneys who provide a mix of paid and pro bono immigration representation and have requested to be added to the platform.
 - b. **ICE will create a list of attorneys who can be called without needing a live person to answer.** ICE will allow attorneys (including those who only provide paid representation) to receive calls from the housing unit phones without needing a live person to answer the telephone. These calls will not be recorded or monitored.
 - c. **ICE will install phone booths in and around housing units for case-related telephone calls.** ICE has agreed to install a total of 40 phone booths that will be distributed among the four Facilities. These phone booths will operate like the housing unit phones, but with more privacy.
 - d. **ICE will ensure access to phone booths.** Except during count and lockdowns, detainees will be able to use phone booths any time during waking hours (including non-free time at Contra Costa). Detainees who are housed in places where they need staff to escort them to a phone booth, such as segregation, will receive access within two waking hours of making a request, absent extraordinary circumstances (which must be reported to ICE). For detainees in disciplinary segregation whose discipline includes limits on telephone access, these requirements apply only to personal or family emergencies, Legal Calls, or calls that are otherwise justified by a compelling need.
 - e. **ICE will extend automatic cut-offs for telephone calls.**
 - i. *Yuba:* Cut-offs for the housing unit phones will be extended from 20 minutes to 40 minutes, and there will be no automatic cut-off in the Yuba phone room.
 - ii. *RCCC:* Cut-offs for the housing unit phones will be extended from 20 minutes to 40 minutes.
 - iii. *All Facilities:* The automatic cut-off for calls from ICE's pro bono platform will be extended to 60 minutes.
 - iv. Based on demonstrated need in individual circumstances, ICE may impose time limits on telephone calls to ensure everyone has access.

2. **There will be more ways to make legal calls from private phone rooms.**
 - a. **Immigration detainees will be allowed to use private phone rooms for legal calls, including calls to non-attorneys.**
 - i. *In general:* These calls will not be recorded or monitored, and will not require a live person to answer. When connecting the call, Facility staff or ICE personnel can check the call recipient's name and ask if the call recipient agrees to speak to the caller, but cannot announce the detainee is calling from a jail or detention facility. If nobody answers, the caller will be able to leave voicemail messages and navigate automated answering systems that require dialing an extension.
 - ii. *Calls to attorneys:* Immigration detainees will be able to call attorneys from these phones for long calls or calls that need extra privacy. Also, attorneys may request calls be scheduled at particular times.
 - iii. *Calls to non-attorneys:* Immigration detainees will be able to call non-attorneys from these phones if the call is case-related (for example, to request a supportive letter or to get help obtaining documents) and the detainee has already tried and been unable to contact the person using a housing unit phone.
 - iv. *RCCC and Yuba:* A phone room, phone booth, or other enclosure will be added to meet this requirement at RCCC, which currently has no private phone room. Privacy will be improved in the Yuba phone room.
 - b. **Phone room calls will be generally limited to 30 minutes but immigration detainees can request longer calls.** However, in periods of high demand, ICE may limit call lengths to ensure everyone has access.
3. **On-site facilitators at each Facility will process telephone requests and provide timely access to phone rooms.** Calls will ordinarily be provided within 8 waking hours, and (except in extraordinary circumstances) always within 24 hours of a request.
4. **Each Facility will take and deliver non-confidential phone and/or email messages related to immigration detainees' immigration cases within 24 hours.**
5. **For detainees who cannot afford to pay for phone calls, ICE will provide extra phone room access or phone credit.** This will be available to detainees who have had less than \$15 on their commissary account for 10 consecutive days at the time of the request.
6. **ICE will make accommodations for international legal calls and three-way calling for legal calls.** There will be a system for requesting international legal calls even if international calls cannot be dialed from housing unit phones or phone rooms. Upon request and statement of a need, such as needing an interpreter to join a call, ICE will facilitate 3-way calls in the Facility (if possible) or at the nearest field office.

7. **ICE will assist people who do not read English or Spanish.** ICE will post a notice in 10 common written languages telling detainees to ask Facility staff for translations of telephone access materials and assistance with telephone access. On request, if local interpretation is not adequate or available, ICE will use a telephone-based “language line” interpreter to provide further explanations. Additionally, if a detainee is trying to call a person who does not speak English and cannot understand the automatic prompts to accept a call, the detainee can use the Phone Room to call that person for case-related calls.
8. **ICE will require training of all local ICE officers with duties related to detention and Facility staff whose duties include supervising detainees or providing telephone access.** ICE will also add detail to the inspection forms it uses in detention facilities across the country to evaluate compliance with detention standards regarding privacy for legal calls, timeliness in responding to telephone requests, availability of message delivery systems, availability of translation and interpretation services, and access to telephones for detainees in segregation.
9. **Five Year Agreement.** ICE will have one year after the Court finally approves the Settlement to make the required changes. The Settlement will be in effect for four years after that. During this time, ICE must provide information to Class Counsel to monitor and enforce the Settlement, including providing various documents and allowing Class Counsel to visit the Facilities to interview detainees.
10. **The Court can enforce the agreement if there are any violations.** The Court will retain jurisdiction over the case to enforce the terms of the Settlement Agreement.
11. **Attorneys’ fees and costs.** The Government will pay \$405,000 to Class Counsel in settlement of all claims for fees and expenses. See below for how to obtain more information about the attorneys’ fees settlement.
12. **Release of claims.** Class Members will release the government from all claims for declaratory or injunctive relief that were brought on behalf of Class Members based on the facts and circumstances alleged in the lawsuit.

For further information:

THIS IS A SUMMARY OF THE AGREEMENT. TO UNDERSTAND IT FULLY, YOU SHOULD READ THE ENTIRE AGREEMENT. You can get copies of the final settlement agreement, Class Counsel’s motion seeking the Court’s approval of the attorneys’ fees provision of the settlement, and copies of this Notice from: 1) Visiting ICE agents; 2) ICE’s website (www.ice.gov); 3) the ACLU of Northern California website (www.aclunc.org/our-work/legal-docket/lyon-v-ice-telephone-access-immigration-detainees); 4) by calling Class Counsel by using speed dial number **#9160** through ICE’s pro bono call platform or by calling (415) 621-2493, ext. 329; 5) the

electronic docket in this case (Case No. 13-cv-05878 EMC), available at <https://ecf.cand.uscourts.gov>; or 6) by writing to Class Counsel at the address listed below:

Class Counsel
Lyon v. ICE Class Action Settlement
c/o ACLU Foundation of Northern California
39 Drumm Street
San Francisco, CA 94111

If calling or writing to Class Counsel, please indicate in your message or letter what you are asking for (a copy of the settlement agreement, the attorneys' fee motion, or the Notice), your name, and how to get in touch with you. If you are in custody, say the detention center where you are currently in custody. If you are out of custody, please provide your address and telephone number.

PLEASE DO NOT TELEPHONE THE COURT OR THE COURT CLERK'S OFFICE TO INQUIRE ABOUT THIS SETTLEMENT.

Procedures for Objecting to the Proposed Settlement:

You can ask the Court to deny approval of the settlement by filing an objection. You cannot ask the Court to order a different settlement; the Court can only approve or deny the settlement. If the Court denies approval, the settlement provisions will not be implemented and the lawsuit will continue. If that is what you want to happen, you must object.

If you object to the proposed settlement, you should do it in writing and must submit the written objection to the Court. Attached to this notice is a sample objection form that you may use to file a written objection. You can request additional copies of this form from ICE agents that visit your detention facility. If you file an objection, you may also choose to appear at the Final Approval Hearing, either in person or through your own attorney. If you appear through your own attorney, you are responsible for paying that attorney if required.

All written objections and supporting papers must:

- (a) Clearly identify the case name and number (*Lyon v. ICE*, Case No. 13-cv-05878 EMC);
- (b) Provide: (i) the Class Member's full name and current detention facility or address, (ii) a signed declaration that the Class Member is a member of the Class, (iii) the specific grounds for the objection, (iv) all documents or writings the Class Member wants the Court to consider, and (v) whether the Class Member intends to appear at the Fairness Hearing.
- (c) Be submitted to the Court either by mailing them to the Class Action Clerk, United States District Court for the Northern District of California, 450 Golden Gate Avenue, San Francisco, CA 94102, or by filing them in person at any location of the United States District Court for the Northern District of California;
- (d) **Be filed or postmarked on or before _____, 2016.**

EXHIBIT C

1 ROBERT P. VARIAN (SBN 107459)
CHARLES J. HA (*pro hac vice*)
2 ALEXIS YEE-GARCIA (SBN 277204)
ORRICK, HERRINGTON & SUTCLIFFE LLP
3 The Orrick Building
405 Howard Street
4 San Francisco, California 94105-2669
Telephone: (415) 773-5700
5 Facsimile: (415) 773-5759
Email: rvarian@orrick.com

6 AMERICAN CIVIL LIBERTIES UNION
7 FOUNDATION OF NORTHERN CALIFORNIA
JULIA HARUMI MASS (SBN 189649)
8 ANGELICA SALCEDA (SBN 296152)
CHRISTINE P. SUN (SBN 218701)
9 MICHAEL T. RISHER (SBN 191627)
39 Drumm Street
10 San Francisco, CA 94111
Telephone: (415) 621-2493
11 Facsimile: (415) 255-8437
Email: jmass@aclunc.org
12 Attorneys for Plaintiffs

13 [Additional Counsel appear on following page]

14 UNITED STATES DISTRICT COURT
15 NORTHERN DISTRICT OF CALIFORNIA
16 SAN FRANCISCO DIVISION

17 AUDLEY BARRINGTON LYON, JR., et al.,
on behalf of themselves and all others similarly
18 situated,

19 Plaintiffs,

20 v.

21 UNITED STATES IMMIGRATION AND
22 CUSTOMS ENFORCEMENT, et al.,

23 Defendants.

Case No.: 13-cv-05878-EMC

**FINAL ORDER APPROVING
SETTLEMENT AND DISMISSING
CASE**

Hon. Edward M. Chen

1 AMERICAN CIVIL LIBERTIES UNION
2 NATIONAL PRISON PROJECT
3 CARL TAKEI (SBN 256229)
4 915 15th Street N.W., 7th Floor
5 Washington, DC 20005
6 Telephone: (202) 393-4930
7 Facsimile: (202) 393-4931
8 Email: ctakei@aclu.org

9 VAN DER HOUT, BRIGAGLIANO, & NIGHTINGALE, LLP
10 MARC VAN DER HOUT (SBN 80778)
11 MEGAN SALLOMI (SBN 300580)
12 180 Sutter Street, Suite 500
13 San Francisco, CA 94104
14 Telephone: (415) 981-3000
15 Facsimile: (415) 981-3003
16 Email: msal@vblaw.com

17 Attorneys for Plaintiffs
18
19
20
21
22
23
24
25
26
27
28

1 WHEREAS Plaintiffs Audley Barrington Lyon, Jr., José Elizandro Astorga-Cervantes,
2 and Nancy Neria-Garcia, on behalf of themselves and all class members (collectively, “Plaintiff
3 Class”), by and through their counsel of record, have asserted claims for declaratory and
4 injunctive relief against Defendants U.S. Immigration and Customs Enforcement (“ICE”); Sarah
5 Saldaña in her official capacity as Director of ICE; the U.S. Department of Homeland Security;
6 Jeh Johnson in his official capacity as Secretary of Homeland Security, and Adrian Macias in his
7 official capacity as Acting Field Office Director for ICE’s San Francisco Field Office
8 (collectively “Defendants”), alleging violations of the Immigration and Nationality Act, 8 U.S.C.
9 § 1101 *et seq.* and the First and Fifth Amendments to the U.S. Constitution; and

10 WHEREAS on April 16, 2014, the Court certified a class of “[a]ll current and future
11 immigration detainees who are or will be held by ICE in in Contra Costa, Sacramento, and Yuba
12 Counties” (ECF No. 31);

13 WHEREAS on July 27, 2015, the Court granted Plaintiffs’ motion to modify the certified
14 class to include “[a]ll current and future adult immigration detainees who are or will be held by
15 ICE in Contra Costa County, Kern County, Sacramento County, or Yuba County” (“Plaintiff
16 Class”) (ECF No. 98);

17 WHEREAS on March 18, 2016, the Court granted in part and denied in part Defendants’
18 motion for summary judgment and denied Plaintiffs’ motion for summary judgment (ECF No.
19 167);

20 WHEREAS the Court found that Plaintiffs’ Counsel are adequate to represent the Plaintiff
21 Class under Federal Rule of Civil Procedure 23(g)(1) and (4), and appointed Plaintiffs’ Counsel
22 as Class Counsel under Rule 23(g) in an Order dated _____, 2016; and

23 WHEREAS the Plaintiff Class and Defendants entered into a settlement of the above-
24 captioned matter (“Settlement”) and executed a Settlement Agreement and Release (“Settlement
25 Agreement”), which has been filed with the Court; and

26 WHEREAS the Court preliminarily approved the Settlement in an Order dated
27 _____, 2016; and
28

1 WHEREAS the Court held a hearing on _____, 2016, where the Court found the
2 Settlement reasonable and fair; and

3 WHEREAS it appears notice of the Settlement has been adequately provided to the Class
4 as provided for by the Court's Order Granting Preliminary Approval; and

5 WHEREAS the Plaintiff Class has filed with the Court a Motion for Final Approval of the
6 Settlement, together with supporting documents; and

7 WHEREAS the Court held a hearing on _____, 2016 to
8 consider the final approval of the Settlement, and any objections to the foregoing filed before or at
9 the time of the hearing;

10 WHEREAS the Court has considered the Settlement between the Plaintiff Class and the
11 Defendants, and the pleadings and documents submitted in connection with the parties' request
12 for final approval of the Settlement, and good cause appearing therefore,

13 **WHEREFORE, IT IS HEREBY ORDERED AS FOLLOWS:**

14 1. The Court has jurisdiction over the subject matter of this action. The Court has
15 personal jurisdiction over the Plaintiff Class (as defined in the Court's orders granting Plaintiffs'
16 motions for class certification and for modification of the class certification order, ECF Nos. 31
17 and 98) and Defendants.

18 2. Under Federal Rule of Civil Procedure 23(e), the Settlement as set forth in the
19 Settlement Agreement is approved as fair, reasonable, adequate, and in the best interests of the
20 Plaintiff Class. The Court finds that the Settlement appears to have resulted from arm's length
21 negotiations by and among counsel for the parties who were reasonably skilled and prepared and
22 who represented the best interests of their respective clients in negotiating the Settlement. The
23 settlement negotiations that led to the Settlement took place in mediations sessions supervised by
24 Magistrate Judge Donna Ryu, with assistance from Magistrate Judge Laurel Beeler. This provides
25 the Court with further assurance that the negotiations leading to the Settlement were good faith,
26 arm's length negotiations, based on a sufficiently developed record, and which appropriately
27 considered the risks of trial, the potential resolution, and all other relevant factors leading to
28 Settlement.

1 3. The Court further finds that the settlement of attorneys' fees and costs in Section
2 XI of the Settlement Agreement was the result of arm's length and good faith negotiations
3 supervised by Magistrate Judges Ryu and Beeler. The attorney's fees and costs provision appears
4 to have taken into consideration the right of Plaintiffs to seek an award of fees that would be
5 substantially higher than the amount agreed to, the risks of trial, and all other relevant factors. The
6 Court therefore approves the award of the Attorneys' Fee Settlement Amount contained in the
7 Settlement Agreement and orders that that the Attorneys' Fee Settlement Amount be paid in
8 accordance with the Settlement Agreement.

9 4. The Court further finds the Notice to the Class was reasonably calculated to
10 apprise the Class of the pendency of this action and all material elements of the proposed
11 settlement, constituted the best notice practicable under the circumstances, and constituted due and
12 sufficient notice.

13 5. This Final Order adopts and incorporates herein by reference in its entirety the
14 Settlement Agreement submitted as Exhibit 1 to the Declaration of Julia Harumi Mass, filed with
15 Plaintiffs' Unopposed Motion for Preliminary Approval of the Class Action Settlement (ECF No.
16 ____). The parties are directed to implement the Settlement Agreement in accordance with its terms
17 and provisions.

18 6. In accordance with Section XII.A of the Settlement Agreement, this action is
19 hereby dismissed with prejudice. Without in any way affecting the finality of this Final Order, this
20 Court retains jurisdiction for the purpose of enforcing the Settlement Agreement and as to all
21 matters relating to the interpretation and enforcement of the Settlement Agreement.

22 7. The Court finds this Final Order adjudicates all of the claims, rights, and liabilities
23 of the Parties to the Settlement, and is intended to be a final judgment within the meaning of Rule
24 54 of the Federal Rules of Civil Procedure.

1 IT IS SO ORDERED.

2

3 Dated _____

4

Hon. Edward M. Chen
U.S. District Court Judge

5

6

7

8

9

10

11

12

13

14

15

16

17

18

19

20

21

22

23

24

25

26

27

28

EXHIBIT D

**NOTICE OF FINAL SETTLEMENT REGARDING TELEPHONE ACCESS IN
IMMIGRATION DETENTION**

LYON, ET AL. V. U.S. IMMIGRATION AND CUSTOMS ENFORCEMENT ET AL.,

Case No. 3:13-cv-05878-EMC

**IN THE UNITED STATES DISTRICT COURT
FOR THE NORTHERN DISTRICT OF CALIFORNIA**

TO: All current and future adult immigration detainees who are or will be held by ICE in Contra Costa County, Kern County, Sacramento County, or Yuba County.

You are hereby notified that on _____, 2016, the Honorable Edward M. Chen of the United States District Court for the Northern District of California approved a settlement of the claims that were brought on your behalf in this lawsuit.

Background on the Lawsuit

This class action lawsuit asserted that U.S. Immigration and Customs Enforcement (ICE) does not provide adequate telephone access for immigration detainees housed in Contra Costa West County Detention Facility, Yuba County Jail, Rio Cosumnes Correctional Center (RCCC), and Mesa Verde Detention Facility (collectively, the Facilities). Specifically, the lawsuit asserted that ICE is violating the statutory and constitutional rights of immigration detainees because the telephone access conditions in the Facilities: (1) prevent detainees from retaining and communicating effectively with lawyers, and (2) prevent detainees from gathering evidence to present in immigration-related proceedings. The parties reached a settlement that the Court has approved.

Description of the Settlement Agreement

Below is a summary of the key points in the settlement agreement. To get a copy of the full agreement, see the section entitled “For Further Information” after this summary.

1. **There will be more ways to make legal calls from housing unit phones and new phone booths for privacy in housing units.**
 - a. **ICE will add speed-dials to make free, direct, unmonitored calls to more government offices and some attorneys from the housing unit phones.** ICE will set up more speed-dial numbers (similar to ICE’s pro bono platform) that will connect without needing a live person to answer and accept the call, that will not be recorded or monitored, and that will be cost-free for the caller and recipient. These numbers will include police departments, probation departments, state and federal courts, and rehabilitation centers as well as attorneys who provide a mix of paid and pro bono immigration representation and have requested to be added to the platform.

- b. **ICE will create a list of attorneys who can be called without needing a live person to answer.** ICE will allow attorneys (including those who only provide paid representation) to receive calls from the housing unit phones without needing a live person to answer the telephone. These calls will not be recorded or monitored.
- c. **ICE will install phone booths in and around housing units for case-related telephone calls.** ICE has agreed to install a total of 40 phone booths that will be distributed among the four Facilities. These phone booths will operate like the housing unit phones, but with more privacy.
- d. **ICE will ensure access to phone booths.** Except during count and lockdowns, detainees will be able to use phone booths any time during waking hours (including non-free time at Contra Costa). Detainees who are housed in places where they need staff to escort them to a phone booth, such as segregation, will receive access within two waking hours of making a request, absent extraordinary circumstances (which must be reported to ICE). For detainees in disciplinary segregation whose discipline includes limits on telephone access, these requirements apply only to personal or family emergencies, Legal Calls, or calls that are otherwise justified by a compelling need.
- e. **ICE will extend automatic cut-offs for telephone calls.**
 - i. *Yuba:* Cut-offs for the housing unit phones will be extended from 20 minutes to 40 minutes, and there will be no automatic cut-off in the Yuba phone room.
 - ii. *RCCC:* Cut-offs for the housing unit phones will be extended from 20 minutes to 40 minutes.
 - iii. *All Facilities:* The automatic cut-off for calls from ICE's pro bono platform will be extended to 60 minutes.
 - iv. Based on demonstrated need in individual circumstances, ICE may impose time limits on telephone calls to ensure everyone has access.

2. **There will be more ways to make legal calls from private phone rooms.**

- a. **Immigration detainees will be allowed to use private phone rooms for legal calls, including calls to non-attorneys.**
 - i. *In general:* These calls will not be recorded or monitored, and will not require a live person to answer. When connecting the call, Facility staff or ICE personnel can check the call recipient's name and ask if the call recipient agrees to speak to the caller, but cannot announce the detainee is calling from a jail or detention facility. If nobody answers, the caller will be able to leave voicemail messages and navigate automated answering systems that require dialing an extension.

- ii. *Calls to attorneys*: Immigration detainees will be able to call attorneys from these phones for long calls or calls that need extra privacy. Also, attorneys may request calls be scheduled at particular times.
 - iii. *Calls to non-attorneys*: Immigration detainees will be able to call non-attorneys from these phones if the call is case-related (for example, to request a supportive letter or to get help obtaining documents) and the detainee has already tried and been unable to contact the person using a housing unit phone.
 - iv. *RCCC and Yuba*: A phone room, phone booth, or other enclosure will be added to meet this requirement at RCCC, which currently has no private phone room. Privacy will be improved in the Yuba phone room.
 - b. **Phone room calls will be generally limited to 30 minutes but immigration detainees can request longer calls.** However, in periods of high demand, ICE may limit call lengths to ensure everyone has access.
3. **On-site facilitators at each Facility will process telephone requests and provide timely access to phone rooms.** Calls will ordinarily be provided within 8 waking hours, and (except in extraordinary circumstances) always within 24 hours of a request.
 4. **Each Facility will take and deliver non-confidential phone and/or email messages related to immigration detainees' immigration cases within 24 hours.**
 5. **For detainees who cannot afford to pay for phone calls, ICE will provide extra phone room access or phone credit.** This will be available to detainees who have had less than \$15 on their commissary account for 10 consecutive days at the time of the request.
 6. **ICE will make accommodations for international legal calls and three-way calling for legal calls.** There will be a system for requesting international legal calls even if international calls cannot be dialed from housing unit phones or phone rooms. Upon request and statement of a need, such as needing an interpreter to join a call, ICE will facilitate 3-way calls in the Facility (if possible) or at the nearest field office.
 7. **ICE will assist people who do not read English or Spanish.** ICE will post a notice in 10 common written languages telling detainees to ask Facility staff for translations of telephone access materials and assistance with telephone access. On request, if local interpretation is not adequate or available, ICE will use a telephone-based "language line" interpreter to provide further explanations. Additionally, if a detainee is trying to call a person who does not speak English and cannot understand the automatic prompts to accept a call, the detainee can use the Phone Room to call that person for case-related calls.
 8. **ICE will require training of all local ICE officers with duties related to detention and Facility staff whose duties include supervising detainees or providing telephone access.** ICE will also add detail to the inspection forms it uses in detention facilities across

the country to evaluate compliance with detention standards regarding privacy for legal calls, timeliness in responding to telephone requests, availability of message delivery systems, availability of translation and interpretation services, and access to telephones for detainees in segregation.

9. **Five Year Agreement.** ICE will have one year after the Court approved the Settlement to make the required changes. The Settlement will be in effect for four years after that. During this time, ICE must provide information to Class Counsel to monitor and enforce the Settlement, including providing various documents and allowing Class Counsel to visit the Facilities to interview detainees.
10. **The Court can enforce the agreement if there are any violations.** The Court will retain jurisdiction over the case to enforce the terms of the Settlement Agreement.
11. **Attorneys' fees and costs.** The Government will pay \$405,000 to Class Counsel in settlement of all claims for fees and expenses. See below for how to obtain more information about the attorneys' fees settlement.
12. **Release of claims.** Class Members will release the government from all claims for declaratory or injunctive relief that were brought on behalf of Class Members based on the facts and circumstances alleged in the lawsuit.

For further information:

THIS IS A SUMMARY OF THE AGREEMENT. TO UNDERSTAND IT FULLY, YOU SHOULD READ THE ENTIRE AGREEMENT. You can get copies of the final settlement agreement from: 1) Visiting ICE agents, 2) ICE's website (www.ice.gov); 3) the ACLU of Northern California website (www.aclunc.org/our-work/legal-docket/lyon-v-ice-telephone-access-immigration-detainees); 4) by calling Class Counsel by using speed dial number **#9160** through ICE's pro bono call platform or by calling (415) 621-2493, ext. 329; or 5) by writing to Class Counsel at the address listed below:

Class Counsel
Lyon v. ICE Class Action Settlement
c/o ACLU Foundation of Northern California
39 Drumm Street
San Francisco, CA 94111

If calling or writing to Class Counsel, please indicate in your message or letter that you are asking for a copy of the settlement agreement, the name of the case (*Lyon v. ICE*), your name, and how to get in touch with you. If you are in custody, say the detention center where you are currently in custody. If you are out of custody, please provide your address and telephone number.